

# ZERO SWING EXCAVATOR TB28FR

Machine Weight:3,095kg(cabin)

## Features

- 1 A compact and truly innovative design enables the TB28FR to efficiently operate in confined areas too narrow for conventional excavators.
- 2 A unique adjustable offset boom system combined with short tail swing radius allows the TB28FR to slew 360 degrees within the excavators track width.
- 3 The TB28FR incorporates a comparably low center of gravity through the location of the excavators heavier components within the lowest possible portions of the machines frame.  
The excavator is designed with the stability and craning capacities of a conventional machine plus the ability to work in exceptionally confined areas.



**TAKEUCHI**

## OPERATING RANGE:mm

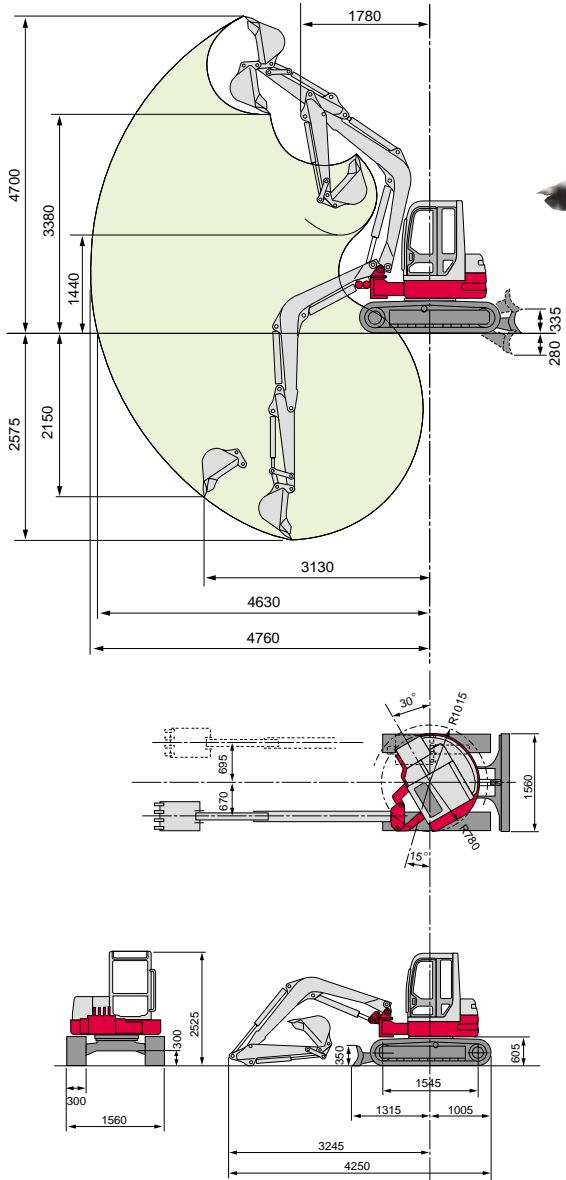

The adjustable one piece offset boom system found on the TB28FR allows for maximum unobstructed digging depths and fast cycle times even when positioned in the fully offset position. Competitive "Zero swing machines" are equipped with cumbersome, multi-part, high maintenance two-piece knuckle boom systems which greatly restrict digging depths when operated in the offset position.



The excavators spacious operators compartment with large comfortable seat provides for hours of fatigue free operation.



When the excavators adjustable boom is placed in the fully offset position the operator may position himself close to the trench for unobstructed visibility and control.

## SPECIFICATIONS TB28FR Cab,Rubber Tracked,Breaker Pippings Standard (Tops/ Fops cabin/ canopy)

WEIGHT: kg		Rear Slew Radius	780	OPERATING RANGE: mm	
Machine Weight	3,095(cabin) 3,010(canopy)	Min. Ground Clearance	300	Max. Dig. Depth	2,575
BUCKET		PERFORMANCES		Max. Vertical Dig. Depth	2,150
Bucket Capa.	m <sup>3</sup> 0.068(SAE, Heaped)	Traction Speed	km/h 2.3/4.1	Max. Dump Height	3,380
Bucket Width	mm 460	Upper Slew Speed	min <sup>-1</sup> 9.6	Max. Dig. Height	4,700
DIESEL ENGINE (WATER-COOLED)		Gradeability	deg/% 30° / 58%	Max. Dig. Radius	4,760
Model	3TNE82A	Max. Dig. Power Bucket	kN 21.9	Max. Floor Dig. Radius	4,630
Type	4CYCL,3CYL,Direct Injection	Arm	kN 15.46	Min. Slew Radius	1,805(On Boom offset: 1,015)
Rated Output	kW 16.8/2,300min <sup>-1</sup>	Ground Press	kPa 30.4(cabin) 29.6(canopy)	Max. Bucket Offset RH/LH	695/ 670
Max.Torque	Nm 84Nm	DOZER BLADE: mm		HYDRAULIC SYSTEM	
Displacement	ml 1,330	Width x Height	1,560x350	Pump	Type 2xVariable Piston Pump+2xGear Pump
Cool Water Capa.	lit 4.5	Operating Range up/down	335/280	Set Press	MPa 20.6x2+19.6+3.4
Lub. Oil Capa.	lit 2.7~3.9	OFF-SET DIG FUNCTION		Discharge	l/min 29.0x2+19.8+10.4
Fuel Tank Capa.	lit 35	Type	Boom Offset	Breaker & Servis Port	l/min 56.8
OVERALL DIMENSIONS: mm		Swing Angle	RH/LH 15 /30	Slew Motor	Axial Piston
Length (in transport)	4,250	TRACTION SYSTEM: mm		Traction Motor	Axial Piston
Width	1,560	Crawler (Track)	Rubber	Hydraulic Tank Capa.	lit 43.5
Height	2,525(cabin) 2,550(canopy)	Track Width :	300		

WORLD CREATOR OF COMPACT EXCAVATOR

## TAKEUCHI MFG.CO.,LTD.

205-3,Uwadaira,Sakaki-machi,Hanishina-gun,  
Nagano 389-0605,Japan

Phone (81)268-81-1112

Telefax (81)268-81-1121

URL <http://www.takeuchi-mfg.co.jp>

E-mail:marketing@takeuchi-mfg.co.jp



ISO 9001  
JIS Q 9001



JAB  
GS Accreditation  
R004

